

**Jeep**



G R A N D C H E R O K E E

This brochure is a publication of Chrysler Group LLC. All product illustrations and specifications are based upon current information at the time of publication approval. Chrysler Group LLC reserves the right to make changes from time to time, without notice or obligation, in prices, specifications, colors, materials, and to change or discontinue models, which are considered necessary to the purpose of product improvement or for reasons of design and or marketing. Jeep, the Jeep grille, CommandView, Go Anywhere, Do Anything, Grand Cherokee, HEMI, Laredo, Overland, Overland Summit, ParkSense, ParkView, Pentastar, Quadra-Drive, Quadra-Lift, Quadra-Trac II, Selec-Terrain, Selec-Track, Sentry Key, Summit, SRT, and Uconnect are registered trademarks and MultiJet II and Selec-Speed are trademarks of Chrysler Group LLC. Alpine and the Alpine logo are registered trademarks of Alpine Electronics, Inc. All rights reserved. Bluetooth is a registered trademark of Bluetooth SIG, Inc. Blu-ray is a trademark and Blu-ray Disc is a registered trademark of Blu-ray Disc Association. Brembo is a registered trademark of Freni Brembo S.p.A. Harman Kardon logo is a registered trademark of Harman International Industries, Inc. © 2015 Chrysler Group LLC. All rights reserved.

<sup>1</sup>No system, no matter how sophisticated, can repeal the laws of physics or overcome careless driving actions. Performance is limited by available traction, which snow, ice, and other conditions can affect. When the ESC warning lamp flashes, the driver needs to use less throttle and adapt speed and driving behavior to prevailing road conditions. Always drive carefully, consistent with conditions. Always wear your seat belt. <sup>2</sup>ACC is a driver convenience system, not a substitute for active driver involvement. The driver must remain aware of traffic conditions and be prepared to use brakes to avoid collisions. <sup>3</sup>Do not attempt water fording unless depth is known to be less than 508 mm. Traversing water can cause damage that may not be covered by the new vehicle warranty. Always off-road responsibly in approved areas. <sup>4</sup>Phone must support Bluetooth Phone Book Access Profile (PBAP). <sup>5</sup>Always look before proceeding, electronic drive aid is not a substitute for conscientious driving. Always be aware of your surroundings. <sup>6</sup>The Advanced Front Air Bags in this vehicle are certified to the new U.S. federal regulations for advanced air bags. Children 12 years old and younger should always ride buckled up in a rear seat. Infants in rear-facing child restraints should never ride in the front seat of a vehicle with a passenger front air bag. All occupants should always wear their lap and shoulder belts properly. <sup>7</sup>Always check visually for vehicles prior to changing lanes. <sup>8</sup>FCW system is solely an alert system for the front of the vehicle which does not take any actions to change vehicle dynamics to avoid a collision, not a substitute for active driver involvement. The driver must remain aware of traffic conditions and be prepared to use brakes to avoid collisions.

14CJUGENT706 (SM)

**Jeep**



DUAL REAR-SEAT  
ENTERTAINMENT SYSTEM

NEW 7-INCH MULTI-VIEW DISPLAY

8.4-INCH TOUCH-SCREEN RADIO

HEATED FRONT- AND SECOND-ROW SEATS

**KEYLESS ENTER 'N GO**

**3.0 V6 DIESEL ENGINE**

NEW 8-SPEED AUTOMATIC TRANSMISSION

SELEC-TERRAIN<sup>®</sup> TRACTION MANAGEMENT

**EXCEPTIONAL OFF-ROAD CAPABILITY**

QUADRA-LIFT<sup>®</sup> AIR SUSPENSION SYSTEM

COMMANDVIEW<sup>®</sup> DUAL-PANE PANORAMIC SUNROOF

NEW HARMAN KARDON<sup>®</sup> 19-SPEAKER PREMIUM AUDIO SYSTEM

NEW NATURA-PLUS LEATHER AND REAL OPEN-PORE WOOD TRIM

**NOTABLE FUEL ECONOMY**

NEW STEERING-WHEEL PADDLE SHIFT CONTROL

OVER 60 AVAILABLE SAFETY AND SECURITY FEATURES

NEW ADAPTIVE HID HEADLAMPS AND LED TAILLAMPS

NEW SELEC-SPEED<sup>™</sup> CONTROL

TODAY IS THE DAY YOU COMMIT TO GREATNESS. NOW IS THE TIME TO GIVE PURPOSE TO YOUR DRIVING PASSION. EVERY MINUTE. EVERY SECOND. NOTHING IS GREATER THAN WHAT LIES AHEAD. THE 2014 JEEP® GRAND CHEROKEE COMPLETELY DEFINES ACHIEVEMENT. HERE, YOU WILL ACHIEVE IT ALL.



GRAND CHEROKEE SUMMIT SHOWN IN CASHMERE PEARL

GRAND CHEROKEE SUMMIT  
WITH THE BEST, YOU  
BECOME THE BEST.



BEAUTIFULLY  
RESILIENT



HARSH WEATHER IS WORRY-FREE WITH GRAND CHEROKEE'S EXPANSIVE MENU OF CAPABILITIES. DESIGNED TO WORK TOGETHER IN TRUE HARMONY, THEY USHER YOU OVER AND THROUGH MOST ANY HINDRANCE MOTHER NATURE LAYS BEFORE YOU. EXPERIENCE LEGENDARY JEEP® BRAND DNA IN ITS MOST ELEGANT FORM.

GRAND CHEROKEE SUMMIT SHOWN IN BRILLIANT BLACK CRYSTAL PEARL



#### AUTHENTIC 4x4 CAPABILITY

Confidence to Go Anywhere, Do Anything® is born and bred in every Jeep® brand transfer case. Choose from two authentic trail-ready four-wheel-drive systems, each engineered to help safely usher you through severe all-weather challenges.

#### ELECTRONIC STABILITY CONTROL<sup>(1)</sup>

Vehicle-wide sensors help keep you moving forward securely, instantly providing aid in stressed and extreme situations.

#### INDEPENDENT SUSPENSION

Independent front and rear suspension systems with isolated cradles help stabilize travel over challenging terrain. Standard.

#### QUADRA-LIFT® SUSPENSION SYSTEM

Gain ultimate control of your system. Raise up to an impressive ground clearance of 287 mm above rocks and snowbanks. Lower it 40.6 mm for easier entry, exit, and loading. Available.

#### SELEC-TERRAIN® TRACTION SYSTEM

Maintain a strong grip on your driving surface. Select from five different "modes," and engage the new Selec-Speed™ for incredible speed control on steep inclines and declines. Coordinates 12 different vehicle management systems. Available.

#### PREMIUM EXTERIOR LIGHTING

Come rain or snow, foggy nights or sunny mornings, Daytime Running Lamps are designed to raise the visibility of your vehicle. With the Signature LED lights, the profile of your Grand Cherokee will rise to very impressive heights. Available Adaptive HID Headlamps follow your cue as you turn the wheel, illuminating road curves for safer visibility. Headlamp washers help maintain visibility during slushy, muddy conditions. A high-pressure spray of washer fluid helps keep your headlamps safely crystal-clear.



EVERY TOUCH IS SUMPTUOUSLY SOFT. EVERY STITCH A MASTERSTROKE.

# PASSION FLOWS WITHIN



GRAND CHEROKEE SUMMIT INTERIOR DASH STITCHING DETAIL SHOWN ON GRAND CANYON — JEEP BROWN LEATHER TRIM



GRAND CHEROKEE SUMMIT LEATHER-TRIMMED SEAT SHOWN IN GRAND CANYON — JEEP BROWN



# GRACIOUSLY BREATHTAKING

GRAND CHEROKEE SUMMIT LEATHER-TRIMMED INTERIOR SHOWN IN GRAND CANYON — JEEP, BROWN

## A BREATHTAKING ACHIEVEMENT

Grand Cherokee Summit achieves the most premium status by delivering an experience that is truly first-class. You're presented with an extensive list of inviting features. Summit owns this benchmark of exclusivity.

## INSPIRED DESIGNER PALETTE

Grand Cherokee Summit is available with a stunning Jeep, Brown interior, inspired by the warm tones that grace the majestic walls of the Grand Canyon. Copper-colored bezels and accent stitching continue the homage to this world wonder.

## ELEGANT TOUCH-POINTS

Premium Natura-Plus leather is featured on Summit's leather-trimmed seats, console, lower instrument panel, and door panels. Real open-pore wood in Summit Brown adorns the instrument panel and door trim. A soft, suede-like headliner adds to the rich appeal of Summit's unique interior design.

## SEATING IN FIRST CLASS

All first- and second-row seats are heated and first-row seats are ventilated for comfort in every climate. Front seats are power-adjustable eight ways, with four-way lumbar adjustment.

## HIGH TECH MEETS HIGH EXPECTATIONS

 Amazing and brilliant, the available Uconnect® 8.4-inch touch screen treats you to a wealth of intuitive features like voice recognition, navigation, climate control, and so much more. And the customizable 7-inch Multi-View Display offers a quick and easy glimpse at a myriad of vehicle systems and driving information.

## LUXURY FOR AUDIOPHILES

For those who appreciate world-class sound design, Harman Kardon® sound engineers have developed an available state-of-the-art system that sends 825 watts of power surging into 19 carefully placed speakers.



THE AUTHENTICITY AND HONESTY OF REAL WOOD EMBODIES TIMELESS BEAUTY AND LASTING STRENGTH.



FINGER-TIP CONTROLS ON YOUR STEERING WHEEL CAN INSTANTLY SCROLL YOU THROUGH A RICH SELECTION OF VEHICLE DATA. IT'S DISPLAYED WITHIN YOUR INSTRUMENT PANEL ON A 7-INCH FULL-COLOR TFT SCREEN. IF KNOWLEDGE IS POWER, THIS VAST ARRAY OF WISDOM MAKES YOU VERY STRONG, INDEED.

#### NAVIGATION

Partnering with available NAV Radio, the Multi-View Display can show turn-by-turn directions, as well as additional details that help you navigate your way.

#### PERFORMANCE

Get real-time fuel economy data. See how many kilometres you can travel before you need to refuel. See how your available Selec-Terrain® system is functioning via perspective visuals.

#### CAPABILITY

See the current setting for your available Quadra-Lift® Suspension System, steering-wheel position, and current wheel articulation.

#### VEHICLE DYNAMICS

Are your tires properly inflated? You'll be notified if the pressure is low on any tire. Driving off-road? See a graphic depiction of how your wheels are articulating.

#### VEHICLE ALERTS

You'll receive visual notification here for safety systems, such as the available Forward Collision Warning<sup>(9)</sup> and Advanced Brake Assist. Set the distance for the available Adaptive Cruise Control.<sup>(2)</sup>



### CONFIGURABLE 7-INCH MULTI-VIEW DISPLAY



MULTI-VIEW DATA CONTROLS

HANDS-FREE VOICE COMMAND CONTROL FOR PHONE, AUDIO, CLIMATE, NAVIGATION, AND MORE

#### GRASP THE FINER THINGS IN LIFE

Leather trim on a newly designed and extraordinarily functional steering wheel. The comforting, available function of approach lamps on exterior mirrors. Keyless Enter 'n Go with push-button start. Delivery of informative vehicle functions with a simple touch of a button. Standard steering-wheel paddle shifters hand over gear shift control to your fingertips. This is how life on the road becomes a highly anticipated event.



REAL WOOD, AVAILABLE

PADDLE SHIFTERS

CRUISE CONTROL

ADAPTIVE CRUISE CONTROL<sup>(2)</sup> AVAILABLE

LEATHER TRIM

## A WORLD-INSPIRED PALETTE

**GRAND CANYON**  
Crafted after the shades of warm brown and amber within the majestic cliffs of the Grand Canyon. Beautiful Copper-colored bezels and accent stitching enhance the overall rich appeal. Available.

**MOROCCO**  
Inspired by the magical shadows of the Marrakech market and the sublime softness of the desert, this classic Black interior shows off Grand Cherokee in luxuriously deep tones. Available.

**NEW ZEALAND**  
A diverse landscape of glaciers, mountains, and rugged coastline provided the insight for a timeless contrast of Black and Light Frost Beige. Available.

**NEPAL**  
Travelers the world over are drawn to the surreal beauty and presence of the Himalayan mountains, where the natural combination of Jeep Brown and Light Frost Beige was derived. Available.

**MT. VESUVIUS**  
This unique pairing of Indigo Blue and Jeep Brown mirrors the evening hues of Italy's Mt. Vesuvius. Open-pore Zebrawood trim, Silver-colored bezels, and accent stitching finish the vision. Available.

OUR DESIGNERS LOOKED TO THE NATURAL HUES FOUND IN SOME OF THE WORLD'S MOST ICONIC LANDSCAPES. THERE, THEY FOUND INSPIRATION THAT TRANSLATES INTO STUNNING INTERIORS CRAFTED WITH LUSH MATERIALS AND THE MOST THOUGHTFUL OF DETAILS.





GRAND CHEROKEE SUMMIT SHOWN IN BRILLIANT BLACK CRYSTAL PEARL



ENLIGHTENED GEM

Bejeweled and utterly refined. Instantly recognizable. Signature LED Daytime Running Lamps make a premium statement that is exclusive to Grand Cherokee.

WITH GRAND CHEROKEE,  
YOUR PASSION FOR  
EXCELLENCE FINDS PURPOSE.



GRAND CHEROKEE OVERLAND<sup>®</sup> SHOWN IN BILLET SILVER METALLIC



EVERY POWERPLANT GAINS EFFICIENCIES.

# MOVE YOUR CAPABILITY EFFICIENTLY FORWARD WITH CLEAN AND POWERFUL DIESEL TECHNOLOGY.

Grand Cherokee's available 3.0 diesel engine delivers the power you need to climb, tow, and go anywhere with confidence. With full command of 184 kW of power and 550 N•m of torque, this strong performer provides a surge of towing strength that can haul up to 3500 kg when properly equipped. The advanced technology of MultiJet™ II common-rail injection and Selective Catalyst Reduction (SCR) work together to help deliver a smooth and quiet ride on the road or trail.

## ECO MODE

This new feature constantly works to maximize your fuel economy by automatically modifying the shift schedule of the 8-speed transmission and torque converter, and gently lowers your idle speed to gain efficiency. The Multi-View Display in your instrument panel can inform you of just how efficiently Eco Mode is performing every kilometre along the way.



### 3.6 V6 PENTASTAR® ENGINE

The Pentastar engine offers an efficient and economical option. Paired with the new 8-speed automatic transmission, it gives you plenty of strength to tow up to 2812 kg when properly equipped — a 24 percent increase in pulling power. Standard.



### 5.7 V8 ENGINE

This available workhorse churns out a maximum towing power of up to 3500 kg when properly equipped. It gives out 259 kW and a brawny 520 N•m, while also employing additional fuel-saving efficiencies thanks to VVT, Fuel Saver Technology, and the new 8-speed transmission. Available.



### 8-SPEED AUTOMATIC TRANSMISSION

It glides with a smooth and quick efficiency, consistently using energy to its best advantage. This is Grand Cherokee's new standard 8-speed automatic transmission. Its construction provides additional gears with no gain in weight, enhanced acceleration with reduced fuel consumption, and increased torque with added strength to pull. This Grand Cherokee drives to engage a new stratum of automotive connoisseurs: SUV motorists who desire a luxurious driving experience paired with an efficient performance. The system's precise design and shift schedule can implement a gear change in 200 milliseconds. This kind of fine tuning can enhance ride quality to levels experienced in the most luxurious sedans. There's excitement as well, by engaging the steering-wheel-mounted paddle shifters when you want to customize your shift schedule. The best possible fuel economies can be attributed to a wide ratio spread that supports lower engine rpm driving in both city traffic and on the highway. When equipped with a two-speed transfer case, crawl ratio is improved by 46 percent, enhancing Grand Cherokee's legendary prowess. Shift into the available Sport Mode and your shift schedule and engine power are both adjusted to hand over a sportier driving experience. It all adds up to a ride that delivers powerful strength without compromise.



WHY STOP AT SIMPLY RAISING THE BAR? THIS IS HOW TO MOVE AHEAD WITH AN AIR-CUSHIONED, ADJUSTABLE RIDE HEIGHT THAT SMOOTHS ON-ROAD HANDLING, INCREASES FUEL EFFICIENCY, EASES ENTRY AND LOADING, AND LIFTS GRAND CHEROKEE TO AMAZING HEIGHTS ... ALL WITH FINGER-TOUCH CONTROL.

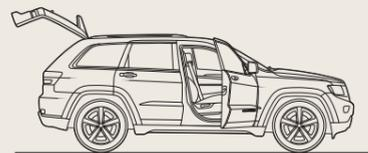

PARK



AERO



OFF-ROAD 1



OFF-ROAD 2



**- PARK // EASIER ENTRY, EXIT, AND LOADING**

In Park Mode, this closed-type air suspension system gently lowers Grand Cherokee -40.6 mm below normal ride height to allow for a more graceful entrance and exit, as well as greater ease loading cargo.



**- AERO // OPTIMAL FUEL EFFICIENCY**

When traveling at cruising speeds, Quadra-Lift automatically lowers the vehicle 15 mm below normal ride height to Aero Mode. This, in turn, improves aerodynamics and fuel efficiency.

# QUADRA-LIFT® AIR SUSPENSION



**+ OFF-ROAD 1 // HELPS CLEAR OBSTACLES**

When you find yourself negotiating deep snow, mud, or two-track trails, switch Quadra-Lift to Off-Road 1 Mode for an added vehicle clearance of 33 mm, giving your capability a serious lift.



**+ OFF-ROAD 2 // CLEARANCE TO OVERCOME**

Quadra-Lift takes you to legendary heights with the simple push of a button. In Off-Road 2 Mode, you'll rise 66 mm above normal ride height, ideal for deep ruts, tall brush, and protruding rocks.

NOTHING IS GREATER  
THAN THIS KIND OF  
GRAND ACHIEVEMENT.



## SAND

Traction control operates with aggressive response to wheel spin. The suspension is raised for optimal performance. Deeper wheel-slip antilock brake settings and off-road-tuned Electronic Stability Control<sup>(1)</sup> are among the primary systems engaged.

## MUD

Quadra-Lift<sup>®</sup> Air Suspension system raises to Off-Road 1 Mode, Traction Control operates with sensitive response to wheel spin, and torque is tuned for optimal performance.

# TERRAIN<sup>®</sup>

TRACTION MANAGEMENT

## ROCK

Raises the vehicle to the maximum ground clearance of 287 mm. The transfer case, differential, and throttle coordinate to provide low-speed control. Electronic Stability Control<sup>(1)</sup> is tuned appropriately for off-road conditions.

## SNOW

Adjusts for ultimate performance over snow- and ice-covered roads by maximizing vehicle stability and minimizing oversteer. Major systems auto-engaged and managed in this Mode include antilock brakes and traction control.



# SELEC-



### SELEC-TERRAIN<sup>®</sup>

Five selectable settings, including a hassle-free Auto Mode, give you ultimate driving confidence by coordinating 12 different vehicle management systems, including throttle control, transmission shifting, transfer case, traction control, and Electronic Stability Control<sup>(1)</sup>. Refined for optimal performance, choose from Sand, Mud, Auto, Snow, and Rock. In Auto, Selec-Terrain does all the work, automatically adjusting vehicle dynamics to best suit the terrain below.

### SELEC-SPEED<sup>™</sup> CONTROL

Selec-Speed adds Hill Ascent Control to the familiar Hill Descent Control. Hill Ascent engages the throttle to help provide stable low-range control when going uphill, where Hill Descent uses engine and physical braking to aid in vehicle control when going downhill.

### JEEP<sup>®</sup> 4x4 CONFIDENCE

Choose from two available 4WD systems:

- + QUADRA-DRIVE<sup>®</sup> II employs an Electronic Limited-Slip Differential that can transfer up to 100 percent of torque to the wheel(s) with traction to help you maintain forward movement.
- + QUADRA-TRAC II<sup>®</sup> offers all-speed traction control that can quickly transfer power to the axle with the most traction.

### TRAIL-READY CAPABILITY

Excel in extreme conditions like mud, sand, snow, and ice when your Grand Cherokee is equipped with an authentic trail-ready 4WD system. Jeep brand 4WD vehicles are made for mastery in five performance categories: Traction, Ground Clearance, Maneuverability, Articulation, and Water Fording.<sup>(3)</sup>



GRAND CHEROKEE OVERLAND.<sup>®</sup>  
THE VIEW EXCEEDS  
EXTRAORDINARY EXPECTATIONS.

**TIMELESS GRANDEUR**

Heritage runs deep within the DNA of Overland, beginning with its name, long associated with the revered Willys-Overland, a legendary vehicle that stands at the forefront of Jeep<sup>®</sup> brand history. Today, Overland carries the legendary torch of strength and honor, with prestigious enhancements that take it to brand-new heights of comfort and luxury. A long list of standard and available features come together to distinguish the name of Overland once again.

**POWER LIFTGATE**

Keep hold of your packages and open the liftgate without any fancy footwork. The available power liftgate adds graceful accessibility to Grand Cherokee's rear cargo area. Keyless Enter 'n Go is hands-free via the key fob, so you can avoid fumbling last minute to unlock the gate.



#### INSPIRED DESIGNER PALETTE

Available for Overland<sup>®</sup>, the Vesuvio interior color scheme of Indigo Blue and Jeep<sup>®</sup> Brown takes its inspiration from the blue-hued and dark-grey walls of Italy's Mt. Vesuvius. Open-pore brown Zebrano wood trim, Silver-colored bezels, and bright accent stitching enhance the overall impact. Vesuvio makes a strong statement with its stunning and unique artistry.

#### DISTINCTIVE AND PLUSH

Overland arrives with a standard, vibrant 8.4-inch Uconnect touch screen with voice operation for available navigation and communication services. First- and second-row seats are leather-trimmed and heated, and first-row seats are ventilated for the utmost cushioned comfort. With the CommandView<sup>™</sup> dual-pane panoramic sunroof, your life on the road is a sunny delight. All this and so much more to experience with the long list of top-shelf premium features standard on Overland.

#### ALPINE<sup>®</sup> PREMIUM AUDIO

Welcome to the Alpine Surround Sound System, standard on Limited and Overland. This premium audio system utilizes a high-powered 12-channel, 506-watt amplifier powering nine speakers and a subwoofer, optimally placed throughout the cabin. A center-channel speaker sits at the front of the cabin. Two 6x9-inch premium cone speakers are situated within the front doors and two 6.5-inch premium speakers are within the rear doors. Two 2.5-inch imaging surround speakers and an 8-inch dual-voice coil subwoofer send clean sound from behind.

#### CLIMATE CONTROL VIA UCONNECT

Create a comfortable cabin using the HVAC controls on the 8.4-inch touch-screen radio with voice operation. You can say, "set driver temp to 22 degrees Celsius," to adjust dual-zone temperatures without ever taking your hands off the wheel.

A STUNNING DISPLAY  
OF DISTINCTION



WHAT A BEAUTIFUL WAY TO STAY CONNECTED. UCONNECT® PUTS YOU IN FULL CONTROL WITH AN AVAILABLE 8.4-INCH TOUCH SCREEN CONVENIENTLY POSITIONED FRONT AND CENTER. HERE, CONTROLS AND INFORMATION COVERING CLIMATE, NAVIGATION, RADIO STATIONS, PHONE STATUS, AND VEHICLE CONTROLS ARE DISPLAYED IN CRYSTAL CLARITY. WELCOME TO COMMAND CENTRAL.



#### NAVIGATION WITH 3-D MAPPING

Use your voice to enter a complete address in one step. Uconnect® will provide mapping on its 8.4-inch touch screen as well as audible turn-by-turn directions. You'll see full-color three-dimensional modeling of urban destinations to help ID landmarks and street junctions. This feature is available with the Uconnect 8.4N radio.



#### HANDS-FREE PHONE<sup>(4)</sup>

Uconnect easily connects with your Bluetooth® compatible phone, and allows quick access to your stored contacts. With Voice Command, you can say who you want to call or text. A standard feature on all radios.



#### VARIETY ENTERTAINMENT

Connect your compatible media device via the USB port, SD card media slot, or 3.5mm auxiliary port.





COMMANDVIEW<sup>®</sup>  
DUAL-PANE SUNROOF



A NEW PERSPECTIVE  
ON LIVING WELL

COMMANDVIEW<sup>®</sup> PANORAMIC SUNROOF

This view from the top is revealing. There's more to be seen when you look up and out via Grand Cherokee's available full-power sunroof with a power sunshade in front and a fixed-glass window in the rear. One look at this dual-paned sliding-glass ceiling and you'll definitely enjoy the best of seeing what comes naturally.

**STYLE.** A new level of opulence is expressed in the exterior details of Grand Cherokee. From a re-envisioned body design, conceived with trim levels unique in appearance, to thoughtful specialties that only a Jeep® vehicle can bear. There's a new capless fuel filler with an electronically locking fuel door that simplifies your stop at the pump, a new available power liftgate for easier access, and thoughtful power mirrors with puddle lamps that light up upon your approach. A signature design for the new projector fog lamps, LED Daytime Running Lamps, and rear taillamps allow Grand Cherokee to see and be seen in a special spotlight.

**LIMITED.** Grand Cherokee Limited arrives with a full array of finery and capability that adds just that much more to every excursion. Luxurious leather-trimmed seating adds plush comfort and go-anywhere Quadra-Trac II® 4WD with Selec-Terrain® with Hill Descent Control expands your destination options. Limited's bright door handles, dual Chrome exhaust tips, and 18-inch polished aluminum wheels add special sparkle.

GRAND CHEROKEE LIMITED.  
DETAILED CRAFTSMANSHIP  
SHINES FROM EVERY  
SCULPTED CORNER.





#### BLU-RAY™ SEATBACK VIDEO SYSTEM

Two available nine-inch VGA high-resolution screens are integrated into the seatback, ready to entertain rear-seat passengers. The system can play standard DVDs as well as Blu-ray Discs,® and includes independent HDMI and RCA inputs for each screen. Includes two wireless headphones.

WHEN YOU SURROUND YOURSELF WITH THE INTRINSIC WARMTH OF MUSIC, IT MAKES YOUR WORLD MORE VIBRANT.



### harman/kardon®

#### HARMAN KARDON® PREMIUM AUDIO

Prestige in audio craftsmanship is reflected in the premium system that arrives standard with Grand Cherokee Summit. This massively powerful system employs 19 GreenEdge speakers, delivering everything an audiophile requires for the replication of sound with the highest of standards. GreenEdge utilizes efficient speaker and amplifier engineering to improve sound quality while significantly diminishing energy consumption.

## 19-SPEAKER HARMAN KARDON PREMIUM AUDIO

- Nine 25-mm Tweeters
- ⊕ Five 90-mm Mid-range Speakers
- Two 160-mm Mid-Woofers
- Two 6x9-inch Subwoofers
- One 10-inch Subwoofer

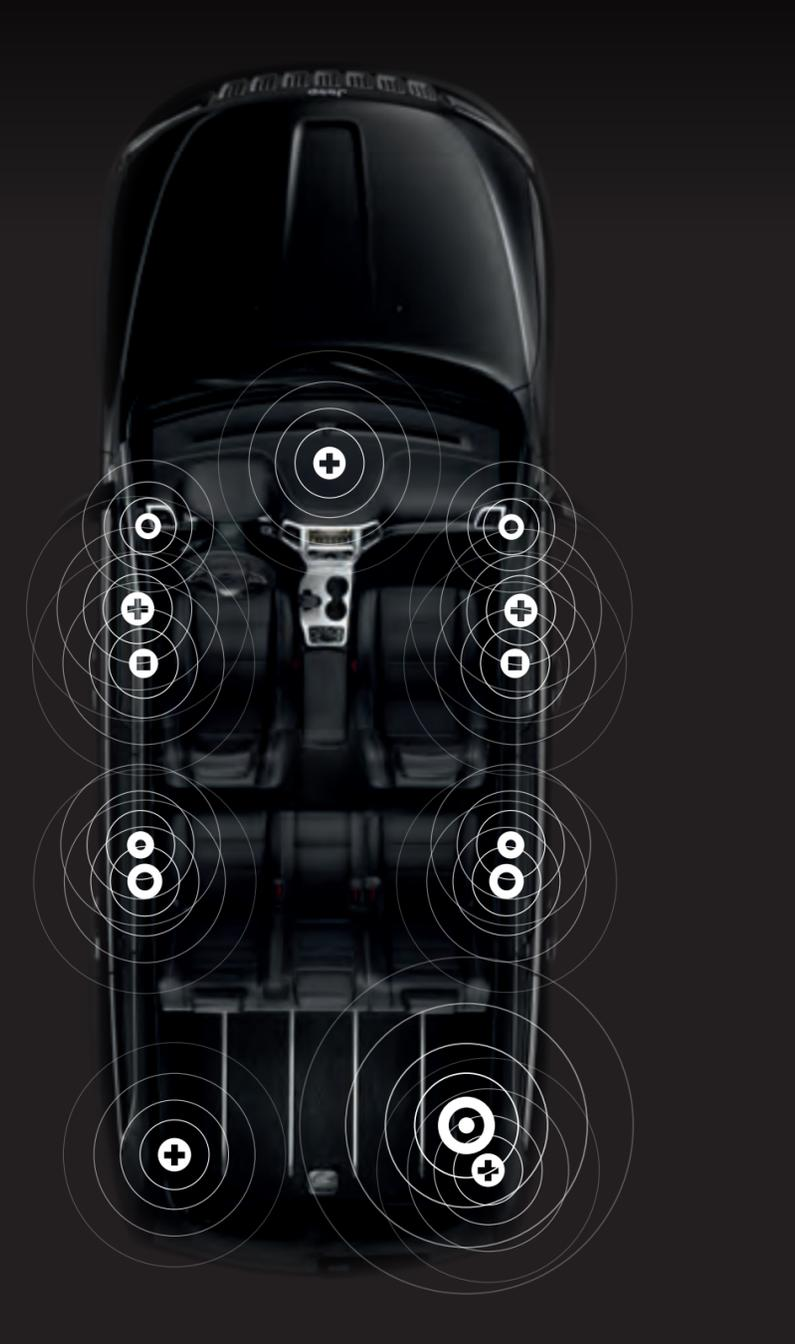

# PEACE OF MIND EVERYWHERE YOU GO.

THE NEW 2014 GRAND CHEROKEE IS RE-IMAGINED AND RE-ENGINEERED TO PERFORM HEROICALLY IN ALL DRIVING CONDITIONS. YOU'LL FEEL THE STRENGTH OF ITS REINFORCED STRUCTURE, SHELTERED WITHIN AN ENVIRONMENT THAT SERVES YOU WELL. GO BOLDLY FORTH, EMPOWERED WITH INSPIRED CONFIDENCE.

## UCONNECT® VOICE COMMAND.

Multitasking is the way of today's world, even when you're on the road. Uconnect Voice Command allows drivers to safely listen to a text, take or make phone calls, request real-time information like fuel prices, get navigation directions, and more, while keeping both hands on the wheel. Available.

## ELECTRONIC STABILITY CONTROL (ESC).<sup>(1)</sup>

A vehicle-wide network of safety sensors helps maintain vehicle control, providing instant aid should they detect you're veering off your intended path. ESC coordinates Electronic Roll Mitigation (ERM), antilock brake system (ABS) and Brake Assist, all-speed traction control, and Trailer Sway Control (TSC), sending them into action when needed. Standard.

## PARKVIEW® REAR BACK-UP CAMERA.<sup>(5)</sup>

Back out safely with grace. This system helps bring previously hidden rear objects to your attention, either on-screen or with an audible warning, in good time to react. Available.

## PARKSENSE® FRONT AND REAR PARK ASSIST SYSTEMS.<sup>(5)</sup>

Grand Cherokee's available Front Park Assist system helps you nestle into parking spots by detecting objects in front of the vehicle and providing an audible warning when your proximity is too close for comfort for you and other drivers. When a side or rear blind spot is encroached, you're notified via illuminated icons on sideview mirrors or an audible chime.

## A SECURE AIR BAG SYSTEM.<sup>(6)</sup>

Your sense of security is fully met with Grand Cherokee's all-around air bag system. Full-length side-curtain, seat-mounted side thorax, and advanced multistage front air bags all work in tandem to help provide protection. Standard.

## ADAPTIVE CRUISE CONTROL (ACC).<sup>(2)</sup>

Take the guesswork out of keeping a safe distance from the car ahead while cruising on the highway. The ACC automatically adjusts cruising speed to maintain a preset distance between your Grand Cherokee and the vehicle in front of you. Available.

**ADAPTIVE HID HEADLAMPS/HEADLAMP WASHERS/SIGNATURE DAYTIME RUNNING LAMPS (DRL).** They follow your cue as you turn the wheel, illuminating curves in the road ahead. Adaptive Headlamps can reveal what was once hidden. Headlamp Washers keep your lenses free of debris. Standard. Signature LED lights offer exceptional daytime visibility.

## TRAILER SWAY CONTROL (TSC).

Crosswinds and traffic hold no sway over you and your payload. As part of ESC,<sup>(1)</sup> TSC helps keep you and the toys you are towing safely on course.

**RAIN-SENSING WIPERS AND RAIN BRAKE SUPPORT.** Storm clouds hold little influence over your daily drive. Front wipers activate when raindrops are detected, and a smart brake system helps dry the brake rotors on wet roads.

## ELECTRONIC ROLL MITIGATION (ERM).

As an extension of ESC,<sup>(1)</sup> ERM employs ESC sensors to anticipate potential risk situations. If things get rough, ERM takes immediate action to help you maintain stability and remain under control. Standard.

## SELEC-SPEED™ CONTROL.

A sense of adventure comes naturally to those living in the world of Jeep, brand capability. Here, capping the top of the mountain is a birthright. However, smoothly navigating steep hills can be a daunting endeavor. Engage Selec-Speed Control on the Selec-Terrain® dial of your 4WD Grand Cherokee and you'll climb and descend with greater safety. Infuses Hill Ascent Control and Hill Descent Control into one incredibly capable feature. Available.

## SENTRY KEY® ENGINE IMMOBILIZER.

A unique, embedded key code matched only to your vehicle helps keep your Grand Cherokee safely where it belongs.

## BLIND SPOT MONITORING<sup>(7)</sup> AND REAR CROSS-PATH DETECTION SYSTEM.<sup>(5)</sup>

These sentry systems constantly monitor the space between you and other vehicles. When a side or rear blind spot is encroached, you're notified via illuminated icons on sideview mirrors or an audible chime. Available.

## FRONT PARK ASSIST.

This available system detects objects in front of the vehicle, providing an audible warning when you're too close for comfort.



GRAND CHEROKEE SUMMIT SHOWN IN CASHMERE PEARL



LAREDO SHOWN IN DEEP CHERRY RED CRYSTAL PEARL, LIMITED SHOWN IN BILLET SILVER METALLIC, OVERLAND® SHOWN IN CASHMERE PEARL, SUMMIT SHOWN IN AUBURN PEARL, SRT® SHOWN IN BRIGHT WHITE



## CHOOSE YOUR PATH TO A REMARKABLE EXPERIENCE.

**LAREDO.** Keyless Enter 'n Go; 3.6 V6 VVT engine; 8-speed automatic transmission; steering-wheel paddle shift control; 7-inch configurable Multi-View Display (EVIC); front and rear air bags<sup>(6)</sup>; 18-inch painted aluminum wheels; projector fog lamps; daytime running headlamps; Uconnect® 5.0 radio (5-inch touch screen, six speakers, and USB media hub); capless fuel fill door; LED taillamps; interior lighting for front footwell, center console bin, Bi-xenon HID headlamps with LED daytime running lamps; power-folding exterior mirrors; headlamp washers; rain-sensing wipers

**LIMITED.** Includes Laredo features, plus or replacing: heated steering wheel; leather-trimmed seating; power eight-way passenger seat with four-way lumbar adjustment; heated front-row and second-row seating; ParkSense® Front and Rear Park Assist<sup>(5)</sup> and ParkView® Rear Back-Up Camera<sup>(5)</sup> with Dynamic Grid Lines; premium audio system with nine speakers, including subwoofer; unique Limited lower fascia; dual exhaust; bright door handles; power, heated, multifunctioning mirrors with courtesy lamps; strakes in rear cargo; door sill scuff pads with bright insert and Jeep, logo

**OVERLAND.®** Includes Limited features, plus or replacing: unique Overland grille; Nappa Leather-trimmed ventilated front seats and leather-stitched instrument panel, door uppers, and center console armrest; real wood and leather-wrapped heated steering wheel; dual-pane sunroof; power liftgate; power tilt/telescoping steering wheel; 20-inch polished wheels with Mineral Gray pockets; Uconnect® 8.4 radio

**SUMMIT.** Includes Overland® features plus or replacing: Natura Plus leather-trimmed seating; Harman Kardon® premium sound system with 19 speakers, including 10-inch subwoofer; adaptive headlamps; 20-inch full polished wheels with Satin clear coat; Blind Spot Detection<sup>(7)</sup>; Forward Collision Warning<sup>(8)</sup>; Adaptive Cruise Control<sup>(2)</sup>

**SRT.®** 6.4-Liter V8 SRT HEMI® engine with Fuel Saver Technology; SRT leather-wrapped steering wheel with audio, EVIC, and cruise controls; SRT Performance Pages; Uconnect Voice Command with Bluetooth®; Keyless Enter 'n Go; Quadra-Trac® Active On-Demand 4-Wheel-Drive System; Selec-Track® Adaptive Damping Suspension with Track, Sport, Auto, Snow, and Tow Modes; Electronic Limited-Slip Rear Differential; SRT Performance Brakes with 6-Piston Front/4-Piston Rear Brembo® Calipers; Uconnect navigation radio with 8.4-inch touch screen; dual heat extractors on hood; steering-wheel-mounted paddle shifters

